

24

WERFVERLICHTING EN ELEKTRICITEIT LAMPES DE CHANTIER ET ÉLECTRICITÉ

WERFLAMPEN	LAMPES DE CHANTIER
ZAKLAMPEN	LAMPES TORCHES
HOOFDLAMPEN	LAMPES FRONTALES
KABELHASPELS	ENROULEURS DE CÂBLE
VERLENGKABELS EN STEKKERS	RALLONGES ET PRISES
VERDEELKASTEN	COFFRET DE DISTRIBUTION
BATTERIJEN	PILES



LUMX[®]
POWER & LIGHTING

SYMBOLIEK / SYMBOLIQUE



Elektrische veiligheidsklasse
Classification de protection électrique



Compatibel met statief
Compatible avec trépied



CE-markering: voldoet aan de eisen zoals vastgelegd in Europese richtlijnen
Marquage CE: conforme aux exigences énoncées dans les directives européennes



IP-classificatie
Classification IP



Energiebesparend
Economie d'énergie

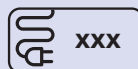

Kabelgegevens
Données du câble



Aantal ingewerkte stopcontacten
Nombre de prises incorporées

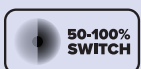
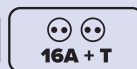

50% en 100% modus
Modes 50% et 100%



25%, 50% en 100% modus
Modes 25%, 50% et 100%



AAN/UIT-schakelaar
Interrupteur ON/OFF



Kantelbaar
Inclinable



Magnetisch onderdeel
Partie magnétique



Bereik sensor
Portée du capteur



Brandtijd lamp
Temporisation du capteur



Lichtsterkte
Intensité lumineuse



Inclusief lader
Chargeur inclus



...u tot volledig opgeladen
Rechargement complet en ...h



Werktijd van ...u
Durée d'utilisation de ...h

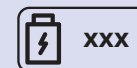

Batterij gebruik
Utilisation de piles



Powerbank functie
Fonction Powerbank



Oplaadbaar via USB of USB-C
Rechargeable via USB ou USB-C



Vervangbare batterij
Batterie remplaçable



Schokbestendig
Résistant aux chocs



USB Connectie
Connection USB



Waterdicht tot 1 m
Résistant à l'eau jusqu'à 1 m



Maximaal koppelen van 10 armaturen
Raccordement maximal de 10 luminaires



LEDS kwaliteit
Qualité des LEDS

KLEURTEMPERATUUR • LA TEMPÉRATURE DE LA COULEUR

De kleurtemperatuur wordt uitgedrukt in Kelvin. Hoe hoger het aantal Kelvin, hoe kouder het licht en omgekeerd.
La température de la couleur est exprimée en Kelvin. Plus le nombre est élevé, plus la lumière est froide et vice versa.

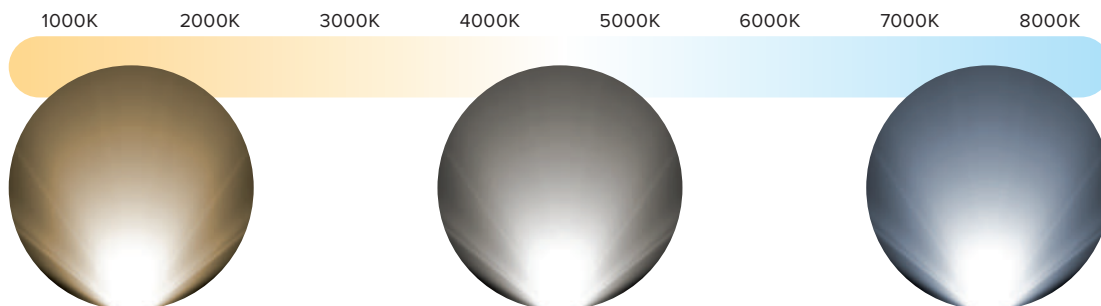

GALAXY COMPACT



P. 523



3 year WARRANTY ON THE LED

GALAXY COMPACT
SMD LED TECHNOLOGY
24W

2500 Lumen

"GALAXY COMPACT LED" 24 W
"GALAXY COMPACT LED" 24 W

code							min.	€	
LM 32232		5420000059320	24 W	290 x 234 x 83 mm	1,720 kg	120	6	1	64,00

GALAXY-Serie



P. 523



4950 Lumen

GALAXY
SMD LED TECHNOLOGY
45W

9200 Lumen

GALAXY XL
SMD LED TECHNOLOGY
80W

"GALAXY LED" - mobiele bouwlamp met verstelbare steun
"GALAXY LED" - lampe de chantier mobile avec support ajustable

code							min.	€	
LM 32245		5420000046498	45 W	385 x 315 x 90 mm	2,300 kg	96	4	1	86,30
LM 32300		5420000065017	80 W	464 x 365 x 84 mm	2,300 kg	64	4	1	131,00

Geschikt voor statief
Apte pour trépied
LM 0225E

LED F-Serie



LED F-20

SMD LED TECHNOLOGY

1800 Lumen

20W



LED F-30

SMD LED TECHNOLOGY

2500 Lumen

30W



LED F-50

SMD LED TECHNOLOGY

4200 Lumen

50W

LED straler F-20 / F-30 / F-50 • Projecteur LED F-20 / F-30 / F-50

code							min.	€	
			mm						
LM 36120		5420000049536	20 W	264 x 238,5 x 148,6	1,438 kg	160	8	1	31,50
LM 36130		5420000049543	30 W	288,6 x 288 x 168,5	1,994 kg	120	6	1	47,30
LM 36150		5420000049550	50 W	318,5 x 308 x 183	2,250 kg	96	4	1	61,00



LED FT-Serie



LED FT-50
SMD LED TECHNOLOGY
50W

4200 Lumen

min. 0,95 m - max. 1,63 m

LED FT-60
SMD LED TECHNOLOGY
2 x 30W

5000 Lumen

min. 0,92 m - max. 1,66 m

LED straler FT-50 / FT-60
Projecteur LED FT-50 / FT-60

code							min.	€	
			mm						
LM 36500		5420000063280	50 W	260 x 285 x 40	5,500 kg	18	2	1	76,10
LM 36660		5420000060135	60 W	570 x 250 x 40	6,100 kg	24	2	1	99,20



LED P+ 60 / LED P+ 100



ALL-IN-ONE

COLOR TEMPERATURE SELECTION

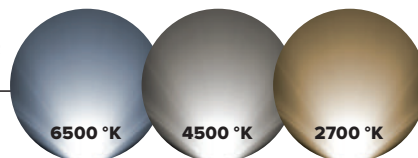

8800 Lumen

LED P+100
SMD LED TECHNOLOGY
100W



5300 Lumen

LED P+60
SMD LED TECHNOLOGY
60W

**LED P+60 / LED P+100 "HIGH POWER" straler
LED P+60 / LED P+100 projecteur "HAUTE PUISSANCE"**

code	mm	min.	€
LM 33595	300 x 305,5 x 82	4	120,00
LM 33600	368 x 346 x 92	4	150,00

LED P-100



LED P-100
SMD LED TECHNOLOGY
100W

11500 Lumen

**LED P-100 "HIGH POWER" straler
LED P-100 projecteur "HAUTE PUISSANCE"**



code	mm	min.	€
LM 33590	342 x 295 x 116	4	129,00

LED LB-50



5500 Lumen

LED LB-50
SMD LED TECHNOLOGY
50W



LED LB-50 Power worklight 360° • LED LB-50 Power worklight 360°



code	mm	min.	€
LM 37500	280 x 286 x 280	4	99,80

LED N-Serie



LED N-50

SMD LED TECHNOLOGY

4580 Lumen

50W

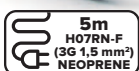

LED N-80

SMD LED TECHNOLOGY

7200 Lumen

80W



LED N-120

SMD LED TECHNOLOGY

10800 Lumen

120W

LED straler N-Serie • Projecteur LED N-Série

code								min.	€
				mm					
LM 34750		542000060050	50 W	330 x 315 x 220	3,115 kg	32	4	1	95,00
LM 34780		542000060067	80 W	400 x 354 x 258	4,682 kg	36	3	1	139,00
LM 34812		542000060074	120 W	500 x 440 x 295	7,500 kg	12	2	1	275,00



LED B-180



16000 Lumen

LED B-180

SMD LED TECHNOLOGY

180W



LED straler B-180 • Projecteur LED B-180

code								min.	€
				mm					
LM 35180		542000060128	180 W	530 x 400 x 360	9,100 kg	16	2	1	295,00

LL-24



LL-24
SMD LED TECHNOLOGY
24W
2650 Lumen



LED LL-24 Doorlusverlichting 24W • LED LL-24 éclairage en boucle 24W

code	Barcode	i	mm	Weight	Length	Width	Height	min.	€
LM 36724	5420000062177		1200 x 72 x 280	1,120 kg	90	6	1		73,70

LS-Serie



inclusief stekker
prise incluse



inclusief stekker
prise incluse



LED lichtslang • Bande LED

code	Barcode	i	mm	Weight	Length	Width	Height	min.	€
LM 23015	5420000070134		380 x 380 x 12	1,600 kg	160	10	1		49,00
LM 23046	5420000065383		264 x 251 x 128	4,300 kg	96	1	1		160,00
Toebehoren voor LS-serie • Accessoires pour LS-série									
LM 23050	5420000062405		-	0,240 kg	-	50	1		16,83

INHOUD - CONTENU :
1x T-connector
3x Pin-connector
3x Eindstuk/embout
1x PVC lijm/colle
1x EU stekker/fiche + kabel/câble
1,5m H05RN-F 2X 1,0 mm²

LED HP-Serie

CLASS 1
 IP 65
 15m HO7RN-F (3G 1,5 mm²) NEOPRENE
 ENERGY SAVING
 6500 °K
 CE

3 year WARRANTY ON THE LED



P. 523

LED HP-150

SMD LED TECHNOLOGY

150W

13400 Lumen

LED HP-200

SMD LED TECHNOLOGY

200W

18250 Lumen

LED HP-400

SMD LED TECHNOLOGY

400W

37600 Lumen



60000 Lumen

LED HP-600

COB LED TECHNOLOGY

600W

HIGH LUMEN

LED straler HP-Serie • Projecteur LED HP-Série

code							min.	€	
mm									
LM 61015		5420000060098	150 W	345 x 280 x 68	6,500 kg	48	2	1	225,00
LM 61020		5420000060104	200 W	425 x 325 x 77	9,000 kg	32	2	1	283,00
LM 61040		5420000060111	400 W	595 x 475 x 95	14,000 kg	18	2	1	525,00
LM 61260		5420000064836	600 W	560 x 470 x 110	18,500 kg	18	1	1	563,00

IP 66

0,3m HO7RN-F (3G 1,5 mm²) NEOPRENE

LED WS-Serie

LED WSS-Serie

CLASS 1
 IP 65
 ENERGY SAVING
 4000 °K
 CE

(((SENSOR)))

WS-20

SMD LED TECHNOLOGY

20W

1800 Lumen

WS-30

SMD LED TECHNOLOGY

30W

2500 Lumen

WS-50

SMD LED TECHNOLOGY

50W

4200 Lumen



WSS-20

SMD LED TECHNOLOGY

20W

1800 Lumen

WSS-30

SMD LED TECHNOLOGY

30W

2500 Lumen

WSS-50

SMD LED TECHNOLOGY

50W

4200 Lumen

LED wandstraler • Projecteur murale LED

code							min.	€	
mm									
WS-Serie • WS-Série									
LM 31320		5420000063785	20 W	174 x 76 x 130	0,640 kg	350	10	1	21,30
LM 31330		5420000063792	30 W	224 x 80 x 168	1,150 kg	288	8	1	32,10
LM 31350		5420000063808	50 W	258 x 83,5 x 192	1,450 kg	180	6	1	44,20
WSS-Serie met sensor • WSS-Série avec détecteur									
LM 31720S		5420000063815	20 W	174 x 76 x 195	0,710 kg	300	10	1	27,70
LM 31730S		5420000063822	30 W	224 x 80 x 250	1,210 kg	144	8	1	42,80
LM 31750S		5420000063839	50 W	258 x 83,5 x 276	1,550 kg	108	6	1	55,60

IP 54

120° - 10m

10 sec - 5 min

5 - 2000 LUX



Multi-battery LED M-Series

CLASS 2
 IP 65
 6500 °K
 3m HO7RN-F (2X 1,0 mm²)
 ON/OFF SWITCH
 25-50-75% 100%-OFF SWITCH
 USB rechargeable
 Changeable battery
 Compatible ACCUPACK 18V battery
 ENERGY SAVING

3 year WARRANTY ON THE LED

220-240V~
50/60Hz

LED M-65
COB LED TECHNOLOGY
65W/18V
MULTI BATTERY HYBRID

NEW



6500 Lumen



MULTI BATTERY
HYBRID 65W 18V

DUAL SYSTEM
BATTERY / CABLE



6 adapters inbegrepen • 6 adaptateurs inclus

- Bosch (LM 30101) • Makita (LM 30102) • Metabo (LM 30103)
- Milwaukee/Dewalt (LM 30104) • Stanley (LM 30105) • Hikoki (LM 30106)



Batterij niet inbegrepen
Batterie non incluse



digitale indicator
van het batterijniveau
indicateur digitale
du niveau de batterie

code						min.	€
------	--	--	--	--	--	------	---

code		mm	W	mm	kg	mm	mm	mm	mm	min.	€
------	--	----	---	----	----	----	----	----	----	------	---

LM 30065		5420000066830	65 W	250 x 157 x 313,5	3,050 kg	48	4	1			139,00
Adapters voor M-Serie en Galaxy Multi-Battery • Adaptateurs pour Série-M et Galaxy Multi-Battery											
LM 30101		5420000066847	BOSCH	-	0,100 kg	-	20	1			3,80
LM 30102		5420000066854	MAKITA	-	0,100 kg	-	20	1			3,80
LM 30103		5420000066861	METABO	-	0,100 kg	-	20	1			3,80
LM 30104		5420000066878	MILWAUKEE/DEWALT	-	0,100 kg	-	20	1			3,80
LM 30105		5420000066885	STANLEY/BLACK&DECKER	-	0,100 kg	-	20	1			3,80
LM 30106		5420000068834	HIKOKI	-	0,100 kg	-	20	1			3,80
Adapter voor bevestiging op statieven • Adaptateur pour montage sur trépieds											
LM 02995		5420000067295	LM 0225E / LM 03305	-	0,230 kg	-	1	1			4,18





Multi-battery LED M-Series



3 year WARRANTY ON THE LED



NEW
LED M-45
COB LED TECHNOLOGY
45W/18V
MULTI BATTERY

4500
Lumen



MULTI BATTERY
45W / **18V**



6 adapters inbegrepen • 6 adaptateurs inclus

- Bosch (LM 30101) • Makita (LM 30102) • Metabo (LM 30103)
- Milwaukee/Dewalt (LM 30104) • Stanley (LM 30105) • Hikoki (LM 30106)

**Adapters voor batterijen zie blz 543
Adaptateurs de batterie voir page 543**

Batterij niet inbegrepen
Batterie non incluse



P. 523



LM 02995

code							min.	€	
			mm						
LM 30000		5420000066823	45 W	230 x 156 x 290	2,230 kg	48	6	1	95,00
Adapter voor bevestiging op statieven • Adaptateur pour montage sur trépieds									
LM 02995		5420000067295	LM 0225E/ LM 03305	-	0,230 kg	-	1	1	4,18

Multi-battery GALAXY Serie



MULTI BATTERY
50W / **18V**

NEW
GALAXY
MULTI BATTERY
SMD LED TECHNOLOGY
50W

5000
Lumen



Batterij niet inbegrepen
Batterie non incluse

6 adapters inbegrepen • 6 adaptateurs inclus

- Bosch (LM 30101) • Makita (LM 30102) • Metabo (LM 30103)
- Milwaukee/Dewalt (LM 30104) • Stanley (LM 30105) • Hikoki (LM 30106)

**Adapters voor batterijen zie blz 543
Adaptateurs de batterie voir page 543**



code							min.	€	
			mm						
LM 30080		5420000067578	50 W	235 x 148 x 388	2,600 kg	44	4	1	98,50



Multi-battery LED MT-100



**MULTI BATTERY
100W 18V**



NEW

LED MT-100
SMD LED TECHNOLOGY
2x50W
MULTI BATTERY

**12000
Lumen**

6 adapters inbegrepen • 6 adaptateurs inclus

Bosch (LM 30201) • Makita (LM 30202) • METABO (LM 30203) •
Milwaukee/Dewalt (LM 30204) • Stanley-Black & Decker (LM 30205)
• Festool (LM 30206)



code								min.	€
------	--	--	--	--	--	--	--	------	---

LM 30200		5420000066892	100 W	1,30 → 1,70	5,400 kg	36	3	1	220,00
----------	--	---------------	-------	-------------	----------	----	---	---	---------------

Adapters voor MT-Serie • Adaptateurs pour Série-MT

LM 30201		5420000066908	BOSCH	-	0,065 kg	-	1	1	5,80
LM 30202		5420000066915	MAKITA	-	0,065 kg	-	1	1	5,80
LM 30203		5420000066922	METABO	-	0,065 kg	-	1	1	5,80
LM 30204		5420000066939	MILWAUKEE/DEWALT	-	0,065 kg	-	1	1	5,80
LM 30205		5420000066946	STANLEY/BLACK&DECKER	-	0,065 kg	-	1	1	5,80
LM 30206		5420000066953	FESTOOL	-	0,065 kg	-	1	1	5,80

LED XS-10

CLASS 3
 IP 54
 6500 °K
 3,7 V 2200 mAh LITHIUM
 ±2-3 hrs
 ±6-8 hrs
 25-50-100% FLASH-OFF SWITCH

incl.
 USB rechargeable
 ENERGY SAVING
 CE



met karabijnhaak
avec mousqueton

LED XS-10
COB LED TECHNOLOGY
10W
RECHARGEABLE

**1000
Lumen**



LED straler XS-10 • LED lampe XS-10

code								min.	€
LM 16410		5420000066236	10 W	100 x 100 x 40 mm	0,663 kg	36	6	1	29,00

LED R-Serie

CLASS 3
 IP 54
 4000 °K
 incl.
 ENERGY SAVING
 CE

LED R-10
SMD LED TECHNOLOGY
10W
RECHARGEABLE



±3-4 hrs
 ±2,5 hrs
 7,4 V 2200 mAh LITHIUM

**800
Lumen**



LED R-20
SMD LED TECHNOLOGY
20W
RECHARGEABLE



±5-6 hrs
 ±2,5 hrs
 7,4 V 4400 mAh LITHIUM

**1600
Lumen**



LED R-10 / R-20 straler op voet • Projecteur LED R-10 / R-20 sur pied

code								min.	€
LM 32110		5420000065444	10 W	239 x 167 x 118 mm	1,040 kg	288	12	1	53,50
LM 32120		5420000065451	20 W	286,5 x 221,5 x 133 mm	1,650 kg	144	8	1	78,70
Lader • Chargeur									
LM 990510		5420000065673	5V - 1,0A (LED R-10)	0,087 kg	-	-	1	1	7,82
LM 990515		5420000065703	5V - 1,5A (LED R-20)	0,087 kg	-	-	1	1	8,11

**MAGNETIC
C feet**



GALAXY



GALAXY R-COMPACT
SMD LED TECHNOLOGY
20W
RECHARGEABLE

GALAXY
SMD LED TECHNOLOGY
30W
RECHARGEABLE

GALAXY • GALAXY

code								min.	€
------	--	--	--	--	--	--	--	------	---

R-Compact rechargeable • R-Compact rechargeable projecteurs PL et LED

LM 32228		5420000059313	20 W	290 x 234 x 68	1,340 kg	200	8	1	81,00
----------	--	---------------	------	----------------	----------	-----	---	---	--------------

Rechargeable • Rechargeable

LM 32230		5420000049161	30 W	385 x 315 x 70	2,300 kg	120	5	1	112,00
----------	--	---------------	------	----------------	----------	-----	---	---	---------------

Lader • Chargeur

LM 991210		5420000065680	GALAXY R-COMPACT 20W		0,142 kg	-	1	1	10,20
-----------	--	---------------	----------------------	--	----------	---	---	---	--------------

LM 991308		5420000065697	GALAXY RECHARGEABLE 30W		0,200 kg	-	1	1	12,97
-----------	--	---------------	-------------------------	--	----------	---	---	---	--------------

Dual LED RS-50 - Hybrid Dual System



DUAL SYSTEM



MAGNETIC foot



LED RS-50
COB LED TECHNOLOGY
50W
RECHARGEABLE/220V

5000 Lumen

digitale indicator van het batterijniveau
indicateur digitale du niveau de batterie



DUAL LED RS-50 • DUAL LED RS-50

code								min.	€
------	--	--	--	--	--	--	--	------	---

LM 30350		5420000049567	50 W	300 x 265 x 130	3,110 kg	96	-	4	1	158,00
----------	--	---------------	------	-----------------	----------	----	---	---	---	---------------

Reserve accu voor LM 30350 • Batterie de recharge pour LM 30350

LM 30355		5420000049574	7,4 V / 8800 mAh	-	0,625 kg	-	-	1	1	70,00
----------	--	---------------	------------------	---	----------	---	---	---	---	--------------

Inclusief batterij • Batterie inclus

LM 30355



STATIEVEN • TRÉPIEDS

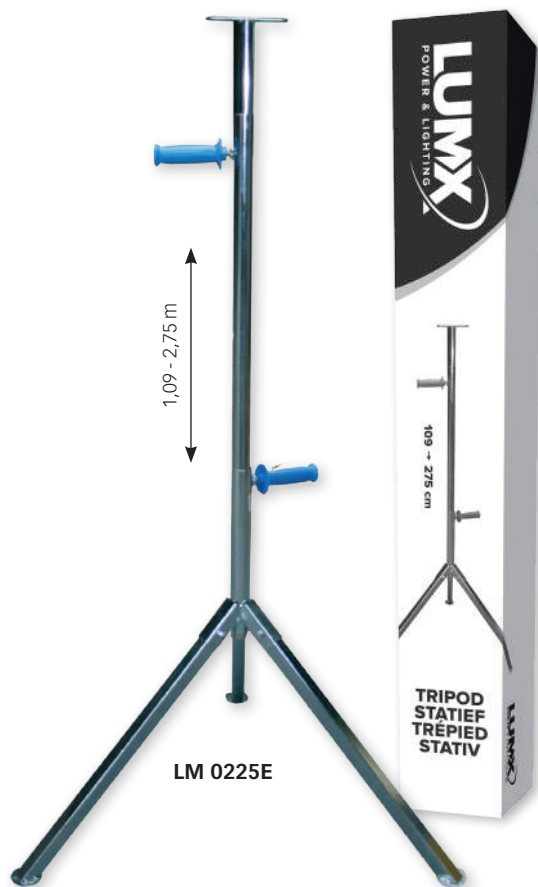

LM 0225E



LM 03305

max
60 kg



extra beveiliging
broche anti-chute



kabelprolsysteem
système d'enroulage
de câble



	LM 0225E	LM 03305
LM 32245	✓	✓
LM 32300	✓	✓
LM 32232	✓	✓
LM 33590	✓	-
LM 33595	✓	-
LM 33600	✓	-
LM 37500	✓	-
LM 61015	✓	✓
LM 61020	✓	✓
LM 61040	✓	✓
LM 61260	✓	✓
LM 30065	✓	✓
LM 30000	✓	✓
LM 30200	-	-
LM 32230	✓	✓
LM 32228	✓	✓
LM 30350	✓	-
LM 02995	✓	✓

code	Barcode	Info	Weight	Stacks	Units	Min.	Price
------	---------	------	--------	--------	-------	------	-------

Statief voor PL- en LED-stralers • Trépied pour projecteurs PL et LED

LM 0225E	5420000018938	1,09 → 2,75 m	6,150 kg	36	3	1	53,90
----------	---------------	---------------	----------	----	---	---	-------

Statief Heavy Duty • Trépied Heavy Duty

LM 03305	5420000062412	1,40 → 3,00 m	7,100 kg	36	2	1	123,00
----------	---------------	---------------	----------	----	---	---	--------

Adapter voor LM 30000 en LM 30065 op statieven
Adaptateur pour LM 30000 et LM 30065 sur trépieds

code	Barcode	Info	Weight	Stacks	Units	Min.	Price
------	---------	------	--------	--------	-------	------	-------

LM 02995	5420000067295	LM 30000 / LM 30065	0,230 kg	-	1	1	4,18
----------	---------------	---------------------	----------	---	---	---	------



NEW

LM 02995

Camelion



**20
Lumen**

Spatwaterbestendige zaklamp "FL-16 LED"
Torche résistante aux éclaboussures "FL-16 LED"

code			lumen					min.	€
PS 011187		4260033155504	20 lm	100 x 180 x 130 mm	0,399 kg	-	12	1	22,39

Batterij excl. • Pile excl.

LM 16360



met draaglint
avec bandoulière



kantelbaar
incluable



**420
Lumen**

LED zaklamp waterproof • Torche LED étanche

NEW

**Meer lumen
+ de lumen !**

code			lumen					min.	€
LM 16360		542000069879	420 lm	188 x 148 x 128 mm	0,680 kg	12	6	1	39,50

Batterij excl. • Pile excl.

T-GUN 950 SPOT LIGHT



Handvrij
Mains libres

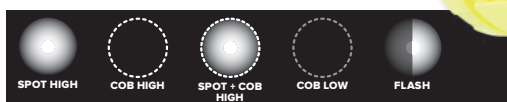

**950
Lumen**

**USB
rechargeable**

LED T-GUN 950 spot light / oplaadbaar / IP67
LED T-GUN 950 spot light / rechargeable / IP67

code			lumen					min.	€
LM 18625		542000064003	950 lm	148 x 165 x 76 mm	0,500 kg	12	3	1	91,10

DUO LED - display 12 st/pcs

CLASS **3**
 IP **20**
4000 °K
20+3
3 x AAA (incl.)
±10 hrs
 ENERGY SAVING

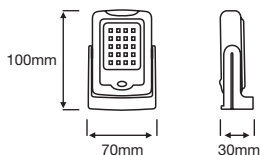

80 Lumen

DUO LED
BULB & SMD LED TECHNOLOGY
BATTERY



code								€
LM 52000	display	5420000039285	mm 100 x 70 x 30	0,094 kg	864	48	12 12	8,73

Prijs per stuk • Prix par pièce



INSPEC DUO GRIP

CLASS **3**
 IP **20**
7000 °K
3,7 V 2600 mAh LITHIUM
USB-C rechargeable
TILTABLE

4 hrs
4 hrs
POWER BANK FUNCTION
 ENERGY SAVING

NEW



30 Lumen

led bulb
led à diode



INSPEC DUO GRIP
COB LED TECHNOLOGY
3W
RECHARGEABLE

300 Lumen

MAGNETIC C-foot



code									€
LM 52114		5420000068469		mm 245 x 58,5 x 45,8	0,387 kg	360	24	1	26,60

SLIM LIGHT

CLASS 3 IP 20 6500 °K USB-C rechargeable ENERGY SAVING SHOCK RESISTANT 2m CE



NEW



MAGNETIC foot

LM 51030
3 W

5 MODES

400 Lumen

3,7 V
800 mAh
LI-ION

±2,5 hrs

±3 hrs



MAGNETIC foot

LM 51250
5 W

5 MODES

600 Lumen

3,7 V
1600 mAh
LI-ION

±3 hrs

±6 hrs



120 Lumen

Display per 10 st.
Display par 10 pcs

code										min.	€
				mm							
LM 51030		5420000068735	3 W	160 x 33 x 20	0,100 kg	480	40	10	1		21,70
LM 51250		5420000068742	5 W	210 x 33 x 20	0,135 kg	480	40	10	1		26,90

INSPEC PRO

CLASS 3 IP 54 5000 °K 3,7 V 4400 mAh LI-ION incl. (TILTABLE) ENERGY SAVING USB-C rechargeable CE

80 Lumen

led bulb
led à diode



800 Lumen

INSPEC PRO
SMD LED TECHNOLOGY
5W
RECHARGEABLE



MAGNETIC foot

code										min.	€
				mm							
LM 52125		5420000042490	5 W	211 x 56 x 38	0,582 kg	360	20	1			44,20

LED T-1000 - display 6 st/pcs

CLASS 3
 LIGHT BY CREE LED S
 IP 66
 7100 °K
 3,7 V 2600 mAh LI-ION
 4 hrs
 USB rechargeable
 POWER BANK FUNCTION

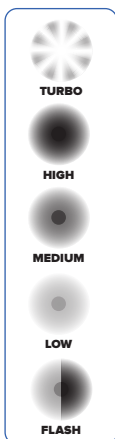

Display per 6 st.
Display par 6 pcs



SMD-Led



1 Micro USB-poort (opladen)
1 USB-poort (Power Bank-functie)
1 port micro USB (charge)
1 port USB (fonction Power Bank)

code									min.	€
LM 15095		5420000063983	10 W	Ø 29 x 150 mm	0,300 kg	192	24	6	1	69,90

TURBO PRO

CLASS 3
 LIGHT BY CREE LED S
 IP 67
 6500 °K
 7,4 V 2600 mAh LI-ION
 ±6 hrs
 incl.
 ENERGY SAVING

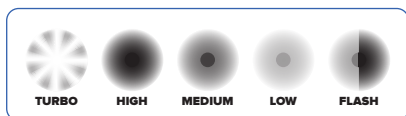

TURBO PRO
SMD LED TECHNOLOGY
28W
RECHARGEABLE

	Lm		
TURBO	3500 Lm	400 m	± 2 u/h
HIGH	1500 Lm	275 m	± 3 u/h
MED	500 Lm	155 m	± 8 u/h
LOW	100 Lm	70 m	± 40 u/h
8HZ FLASHING	N/A	N/A	± 8 u/h

1 METER
SUBMERSIBLE



met LOCK-systeem
avec LOCK-système



LED-zaklamp TURBO PRO High Power
Torche LED TURBO PRO High Power

code			lumen						min.	€
LM 17005	koffer/coffre	5420000060579	3500 lm	Ø 62 x 247	0,600 kg	72	4	2	1	172,00

HL-250

LIGHT BY **CREE** LEDs
IP 64
SHOCK RESISTANT 2m
USB rechargeable
Changeable battery
6100 °K
7100 °K
 ±2,5 hrs
 Incl. 3,7 V 800 mAh LFPOLYMER
 of **OU**
 3 x AAA (not incl.)
CE

90° kantelbaar
Inclinaison à 90°
 Verstelbare focus
Mise au point réglable
 Dubbele lichtbron
Deux sources de lumière



250 Lumen



LED hoofdlamp HL-250 met herlaadbare batterij
LED lampe frontale HL-250 avec batterie rechargeable

code		lumen						min.	€
LM 12325		250 lm	62 x 41 x 43 mm	0,130 kg	288	24	6	1	47,70
Batterij voor LM 12325 • Batterie pour LM 12325									
LM 12997		-	43 x 32 x 11 mm	0,020 kg	-	-	1	1	18,50



LM 12997

HL-350

LIGHT BY **CREE** LEDs
IP X4
 ±2,5 hrs
CE
 Incl. 3,7 V 1200 mAh LITHIUM
SHOCK RESISTANT 2m
USB rechargeable
(SENSOR)
Flexible rubber band



350 Lumen

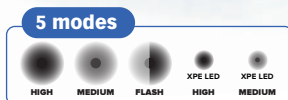

LED hoofdlamp HL-350 met sensor
LED lampe frontale HL-350 avec sensor

code		lumen						min.	€
LM 12005		350 lm	125 x 35 x 25 mm	0,510 kg	-	48	12	1	18,00



XPE LED

COB LED

TCT-250S

LUMILEDS
The Brighter Choice
IP X4
 3 x AAA DURACELL (incl.)
SHOCK RESISTANT 2m
6500 °K
 Met lichtsensor
Avec capteur de lumière
PULSE MODE
Met pulse mode
Avec mode pulse
 Met bewegingssensor
Avec capteur de mouvement
CE



250 Lumen

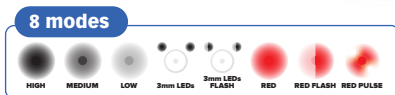

LED hoofdlamp TCT-250S met sensor
LED lampe frontale TCT-250S avec sensor

code		lumen						min.	€
LM 12440		250 lm	36 x 82 x 37 mm	0,150 kg	288	24	6	1	38,00



TCT-300

LIGHT BY CREE LEDs
 IP 64
 Incl. 3,7 V 2600 mAh Li-ion
 ±4 hrs
 7100 °K 8300 °K
 CE
 SHOCK RESISTANT 2m
 USB rechargeable
 Changeable battery

6 modes

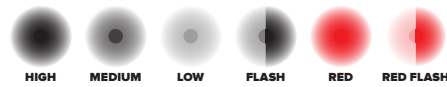

300 Lumen

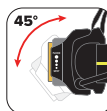

45° kantelbaar
Inclinaison à 45°



Met rood achterlicht
Avec feu arrière rouge

Antislip strip
Bande antidérapante

Verstelbare focus
Mise au point réglable

LED hoofdlamp TCT-300 met herlaadbare batterij LED lampe frontale TCT-300 avec batterie rechargeable

code		lumen					min.	€
LM 12590		300 lm	79 x 44 x 38 mm	0,240 kg	288	24	6	1 61,40
Batterij voor LM 12590 • Batterie pour LM 12590								
LM 12998		-	71 x Ø 19 mm	0,048 kg	-	-	1	1 20,00



LM 12998

TCT-375B

LUMINUS
 IP 64
 3 x AA DURACELL (incl.)
 SHOCK RESISTANT 2m
 7500 °K
 CE

6 modes

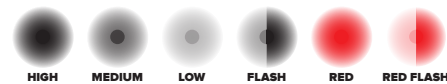

375 Lumen

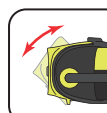

180° kantelbaar
Inclinaison à 180°

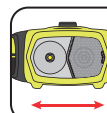

Met verschuifbare diffuser
Avec diffuseur coulissant



Met rood achterlicht
Avec lumière arrière rouge

Antislip strip
Bande antidérapante

LED hoofdlamp TCT-375B LED lampe frontale TCT-375B

code		lumen					min.	€
LM 12195		375 lm	38 x 70 x 50 mm	0,120 kg	192	24	6	1 31,10

FOCUSED

DIFFUSED



TCT-640

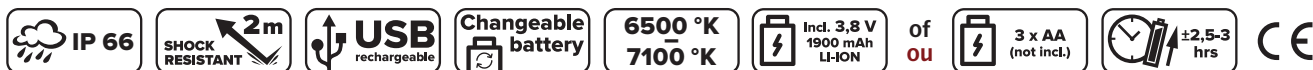

6 modes

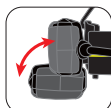
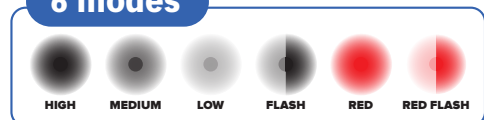

90° kantelbaar
Inclinaison à 90°



Met rood achterlicht
Avec lumière arrière rouge

Antislip strip
Bande antidérapante



Ultrabreed
Ultra-large

**LED hoofdlamp TCT-640 herlaadbaar
LED lampe frontale TCT-640 rechargeable**



LM 12999

code	Barcode	lumen	mm	g	mm	mm	mm	mm	min.	€
LM 12600	5420000063068	640 lm	125 x 35 x 25	0,200 kg	192	24	6	1		69,00
Batterij voor LM 12600 • Batterie pour LM 12600										
LM 12999	5420000063075	-	47 x 45 x 14	0,040 kg	-	-	-	10	1	29,50

TCT-755 / EXTRA LONG AUTONOMY - AUTONOMIE EXTRA LONGUE

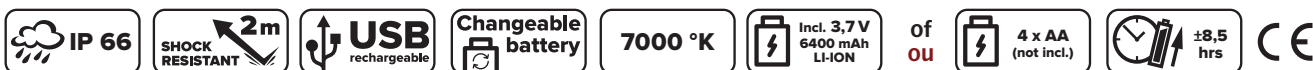

6 modes

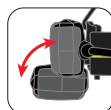
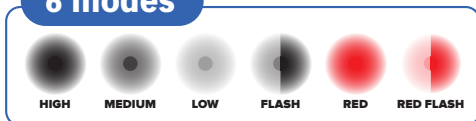

90° kantelbaar
Inclinaison à 90°



Met rood achterlicht
Avec lumière arrière rouge

Antislip strip
Bande antidérapante

NEW

**755
Lumen**



Verstelbare focus
Mise au point réglable



code	Barcode	lumen	mm	g	mm	mm	mm	mm	min.	€
LM 12755	5420000068773	755 lm	79 x 44 x 38	0,410 kg	-	24	6	1		89,00
Batterij voor LM 12755 • Batterie pour LM 12755										
LM 12996	5420000068780	-	77 x 25 x 20	0,130 kg	-	-	-	10	1	45,40

PRO

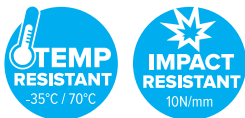

Thermische schakelaar
Disjoncteur thermique

Trommel kunststof
Tambour plastique

PRO

NEOPRENE
HEAVY DUTY



Kabelhaspel PRO
Enrouleurs de câble PRO

code									€
			m	2P+A / 2P+T					
LM 85025		5420000032255	25	4 x + klapdeksels / clapets	8,100 kg	36	2	1	102,00
LM 85140		5420000063662	40	4 x + klapdeksels / clapets	12,000 kg	36	2	1	139,00

XT PRO

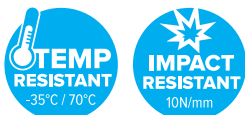

Thermische schakelaar
Disjoncteur thermique

Trommel kunststof
Tambour plastique

XT

PRO
NEOPRENE
HEAVY DUTY



Kabelhaspel XT PRO
Enrouleurs de câble XT PRO

code									€
			m	2P+A / 2P+T					
LM 87240		5420000060616	40	4 x + klapdeksels / clapets		24	2	1	159,00
LM 87278		5420000060623	40	4 x + klapdeksels / clapets		24	2	1	159,00

XT PREMIUM



Thermische schakelaar
Disjoncteur thermique

Trommel aluminium
Tambour alu

XT

PREMIUM
PUR
HEAVY DUTY



code									€
			m	2P+A / 2P+T					
LM 88740		5420000060630	40	4 x + klapdeksels / clapets		24	2	1	225,00

PRO 3-WAY

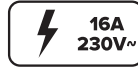

PRO
3 - WAY
NEOPRENE
HEAVY DUTY

Thermische schakelaar
Disjoncteur thermique



Trommel kunststof
Tambour plastique



Kabelhaspel PRO met driewegskoppelstekker
Enrouleurs de câble PRO avec fiche femelle triple

code								min.	€	
LM 85728		5420000043633	25 m	2P+A / 2P+T	3 x + klapdeksels / clapets	8,360 kg	36	2	1	134,00



XT PRO

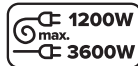

XT
PRO
NEOPRENE
HEAVY DUTY



Thermische schakelaar
Disjoncteur thermique

Trommel kunststof
Tambour plastique

35M



Kabelhaspel XT PRO NO-TURN
Enrouleurs de câble XT PRO NO-TURN

code								min.	€	
LM 87635		5420000065291	35 m	2P+A / 2P+T	4 x + klapdeksels / clapets	10,630 kg	24	2	1	149,00

BS HOME

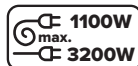

BS
HOME
VINYL



Thermische schakelaar
Disjoncteur thermique

Trommel kunststof
Tambour plastique

LM 80025



LM 80050

Standaard kabelhaspel BS HOME
Enrouleurs de câble standard BS HOME

code								min.	€	
LM 80025		5420000025004	25 m	2P+A / 2P+T	4 x	4,010 kg	80	4	1	55,40
LM 80050		5420000025011	50 m	2P+A / 2P+T	4 x	6,800 kg	48	2	1	94,90

NEW

1600W
max.
3000W

3x
BE/FR

10m
H07RN-F
(3G 2,5mm²)
NEOPRENE



LM 84015

800W
max.
2000W

15m
H05VV-F
(3G 1,5mm²)
VINYL

1x
BE/FR



LM 84110

ROLL-UP 3-WAY NEOPRENE

WALLMOUNT



ROLL-UP 1-WAY VINYL

Kabelhaspel ROLL-UP
Enrouleurs de câble ROLL-UP



code								min.	€
LM 84015		5420000068803	205 x 290 x 290					1	189,00
LM 84110		5420000068810	205 x 290 x 290					1	259,00

	LM 84015	LM 84110
Kabel type / Type de câble	H05VV-F / 3G 1,5 mm ²	H07RN-F / 3G 2,5 mm ²
Kabellengte / Longueur de câble	15 m	10 m
Max. Watt	2000W	3000W
Stekkers / Prises		

NEW



ROLL-UP DUO AIR / WATER

MAX
40° C

MAX
15 BAR



Persluchtlanghaspel ROLL-UP DUO
Enrouleur de tuyau à air comprimé ROLL-UP DUO

code							min.	€
LM 84212		5420000068827	210 x 330 x 360					166,00



WALLMOUNT

	LM 84212
Slanglengte / Longueur du tuyau	12 m
Max. water temp. / Temp. max. eau	40° C
Max. luchtdruk / Pression de l'air max.	15 BAR
Invoer / Entrée	1/4" F
Uitvoer / Sortie	1/4" M



LM 40625



25 m.

LM 40515
LM 40526



LM 40745 - LM 40750
LM 40755 - LM 40765
LM 40770



**Verlengkabel - stopcontact met klapdeksel
Rallonge - prise avec clapet**

code									min.	€
H05VV-F										
			m							
LM 40515	vrac	5420000039681	15	3G 1,5 mm ²	1,580 kg	200	8	1		26,80
LM 40526	vrac	5420000034945	25	3G 1,5 mm ²	3,100 kg	144	4	1		43,30
H07RN-F										
LM 40745	vrac	5420000041554	5	3G 2,5 mm ²	1,265 kg	180	10	1		19,10
LM 40750	vrac	5420000019607	10	3G 2,5 mm ²	2,300 kg	144	4	1		33,80
LM 40755	vrac	5420000041561	15	3G 2,5 mm ²	3,790 kg	90	5	1		51,40
LM 40765	vrac	5420000019614	25	3G 2,5 mm ²	5,400 kg	104	2	1		76,00
LM 40770	vrac	5420000047488	40	3G 2,5 mm ²	8,640 kg	60	2	1		138,00
Met vervangbare stekkers en stopcontact • Avec prise mâle et femelle remplaçable										
LM 40605	polybag	5420000067776	5	3G 2,5 mm ²	1,100 kg	100	50	1		38,50
LM 40625	polybag	5420000066731	25	3G 2,5 mm ²	7,196 kg	35	1	1		138,00

LM 40453



LM 40435



LM 40425



LM 40455



LM 40443 - LM 40445



Max. 3600 W

**Machine aansluitkabel
Cordon de raccordement machine**



EE 80600470



code									min.	€
H05RN-F										
			m							
LM 40425	vrac	5420000047334	5	2 x 1,0 mm ²	0,420 kg	280	20	1		6,72
H07RN-F										
LM 40453	vrac	5420000041530	3	2 x 1,0 mm ²	0,320 kg	450	30	1		5,56
LM 40455	vrac	5420000041547	5	2 x 1,0 mm ²	0,510 kg	600	20	1		8,05
LM 40443	vrac	5420000041516	3	2 x 1,5 mm ²	0,420 kg	270	30	1		6,22
LM 40445	vrac	5420000041523	5	2 x 1,5 mm ²	0,696 kg	280	20	1		10,29
LM 40435	vrac	5420000041509	5	3G 1,5 mm ²	0,850 kg	280	20	1		13,13
H07BQ-F										
EE 80600470	vrac	5420000058996	3	2 x 1,0 mm ²	0,100 kg	-	1	1		16,40



Stekker en stopcontact - 2P + A Prise mâle et prise femelle - 2P + T

230V - 50Hz

code						min.	€
------	--	--	--	--	--	------	---

Stekker • Prise mâle

LM 48521	vrac	5420000046900	rubber / caoutchouc	0,072 kg	-	30	1	4,14
----------	------	---------------	---------------------	----------	---	----	---	-------------

Stopcontact met klapdeksel • Prise femelle avec clapet

LM 48411	vrac	5420000046917	rubber / caoutchouc	0,102 kg	-	20	1	7,38
----------	------	---------------	---------------------	----------	---	----	---	-------------



Stekker en stopcontact "Dual System" - 2P + A Prise mâle et prise femelle "Dual System" - 2P + T

230V - 50Hz

code						min.	€
------	--	--	--	--	--	------	---

Stekker • Prise mâle

LM 48585	vrac	5420000046931	rubber / caoutchouc	0,094 kg	-	20	1	5,64
----------	------	---------------	---------------------	----------	---	----	---	-------------

Stopcontact met klapdeksel • Prise femelle avec clapet

LM 48455	vrac	5420000046924	rubber / caoutchouc	0,134 kg	-	10	1	8,10
----------	------	---------------	---------------------	----------	---	----	---	-------------



Contactblok met klapdeksels - 2P + A Prise à clapets - 2P + T

230V - 50Hz

code						min.	€
------	--	--	--	--	--	------	---

Dubbel • Double

LM 48200	vrac	5420000046979	-	0,222 kg	-	10	1	22,92
----------	------	---------------	---	----------	---	----	---	--------------

3-voudig • Triple

LM 48300	vrac	5420000046948	-	0,317 kg	-	5	1	36,50
LM 48310	zakje/sachet	5420000046955	10	H07RN-F/3G 2,5 mm ²	5,350 kg	-	1	87,10
LM 48325	zakje/sachet	5420000046962	25	H07RN-F/3G 2,5 mm ²	6,100 kg	-	1	134,40

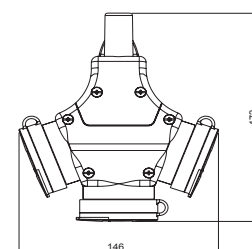

NI 243300



Driewegskoppelstekker • Fiche femelle triple

250V - 16A

code							min.	€
NI 243300			block	0,220 kg	-	50	1	10,20
NI 243303			0,3 m kabel / câble 0,3 m	0,370 kg	-	30	1	14,50
NI 243305			5 m kabel / câble 5 m	1,370 kg	-	20	1	27,00
NI 243310			10 m kabel / câble 10 m	2,520 kg	-	8	1	41,70
NI 243325			25 m kabel / câble 25 m	5,970 kg	-	4	1	79,00

NI 243303



Verdeelblok met 4 stopcontacten en schakelaar - EN60309

Bloc multiprises avec 4 prises et interrupteur - EN60309

250V - 16A

code							min.	€
LM 41200			block	0,458 kg	-	10	1	25,36
LM 41203			3 m kabel / câble 3 m	1,118 kg	-	10	1	41,75
LM 41210			10 m kabel / câble 10 m	2,200 kg	-	4	1	57,90



Dominostekker 2-voudig • Prise domino 2 entrées

250V - 16A



code							min.	€
LM 40800			block	0,200 kg	-	60	1	2,51

LM 40803

LM 40814

LM 40913

LM 40826



Stekkerdoos met schakelaar • Prise avec interrupteur

250V - 50Hz

code							min.	€
3-voudig • Triple								
LM 40803			1,5 m kabel / câble 1,5 m	0,263 kg	-	40	1	7,39
4-voudig • Quadruple								
LM 40814			3 m kabel / câble 3 m	0,429 kg	-	30	1	10,43
6-voudig • Sextuple								
LM 40826			5 m kabel / câble 5 m	0,742 kg	-	20	1	15,28
3-voudig + 2 USB-connecties • Triple + 2 connections USB								
LM 40913			1,5 m kabel / câble 1,5 m	0,388 kg	-	40	1	13,21

3P+N+A / 3P+N+T
400V - 16A



LM 44110 - LM 44125

3P+N+A / 3P+N+T
400V - 32A



LM 44345

3P+N+A / 3P+N+T
400V - 32A



LM 44566

3P+N+A / 3P+N+T
400V - 64A



LM 44580

Neopreen verlengkabels EN 60309 Rallonges néoprène - EN 60309



code												
			Kabel/Câble	Ampère	Polig / Pôles				min.	€		
LM 44102	polybag	5420000043015	2 m / 3G 2,5 mm ²	16A	3 polig / pôles	0,680 kg	-	25	1	14,50		
LM 44105	polybag	5420000066656	5 m / 3G 2,5 mm ²	16A	3 polig / pôles	1,250 kg	-	10	1	23,20		
LM 44110	polybag	5420000043022	10 m / 5G 2,5 mm ²	16A	5 polig / pôles	3,147 kg	-	4	1	69,40		
LM 44125	polybag	5420000043039	25 m / 5G 2,5 mm ²	16A	5 polig / pôles	7,196 kg	-	2	1	129,20		
LM 44345	polybag	5420000043046	25 m / 5G 4 mm ²	32A	5 polig / pôles	14,090 kg	-	1	1	236,00		
LM 44566	polybag	5420000043053	25 m / 5G 6 mm ²	32A	5 polig / pôles	20,340 kg	-	1	1	315,60		
LM 44580	polybag	5420000044326	25 m / 5G 10 mm ²	64A	5 polig / pôles	31,000 kg	-	1	1	688,00		

2P+A / 2P+T
250V - 16A



LM 44102
LM 44105



LM 44730



LM 44835

LM 44751



LM 44861

LM 44753



LM 44863

LM 44616
LM 44632



LM 44646
LM 44662



POWER-GRIP

CEE stekkers (M) - koppelstekkers (V) - EN 60309 Fiches CEE male - femelle - EN 60309

code											
			Ampère	Polig / Pôles					min.	€	



CEE stekker (M) • Fiche CEE male

LM 44730	polybag	5420000043060	16A	3 polig / pôles	0,111 kg	-	10	1	3,82		
LM 44751	polybag	5420000043077	16A	5 polig / pôles	0,144 kg	-	10	1	4,65		
LM 44753	polybag	5420000043084	32A	5 polig / pôles	0,217 kg	-	10	1	7,02		
LM 44755	polybag	5420000043091	63A	5 polig / pôles	0,700 kg	-	5	1	33,40		
LM 44646		5420000066700	16A	5 polig / pôles	0,184 kg	-	10	1	9,35		
LM 44662		5420000066717	32A	5 polig / pôles	0,278 kg	-	10	1	12,55		

LM 44755



LM 44865

CEE koppelstekker (F) • Fiche CEE femelle

LM 44835	polybag	5420000043114	16A	3 polig / pôles	0,133 kg	-	10	1	5,00		
LM 44861	polybag	5420000043121	16A	5 polig / pôles	0,183 kg	-	10	1	5,68		
LM 44863	polybag	5420000043138	32A	5 polig / pôles	0,283 kg	-	10	1	7,75		
LM 44865	polybag	5420000043145	63A	5 polig / pôles	0,825 kg	-	5	1	42,70		
LM 44616		5420000066687	16A	5 polig / pôles	0,216 kg	-	10	1	12,60		
LM 44632		5420000066694	32A	5 polig / pôles	0,312 kg	-	10	1	14,82		





Muurstekker combo - 1 x CEE 16A-400V - 1 x 16A-230V / BE-FR
Prise murale combo - 1 x CEE 16A-400V - 1 x 16A-230V / BE-FR



code							min.	€
LM 46003		5420000066724	200 x 80 x 68 mm	0,426 kg	-	5	1	27,00

ISO 9001



LM 46101



LM 46105

code							min.	€
250 - 400 V								
LM 46101		5420000049376	240 x 100 x 80 mm	0,565 kg	-	2	1	42,90
LM 46105		5420000047099	240 x 100 x 80 mm	1,120 kg	-	2	1	121,00
400 V								
LM 46120		5420000047105	200 x 170 x 80 mm	0,744 kg	-	2	1	48,80
LM 46122		5420000047112	240 x 170 x 80 mm	1,320 kg	-	2	1	100,00



LM 46120



LM 46122



	LM 46101	LM 46105	LM 46120	LM 46122
Invoer / Entrée	1 x CEE 16A - 5P - 400V			
Uitvoer / Sortie	1 x CEE 16A - 5P - 400V 2 x 16A - 250V		3 x CEE 16A - 5P - 400V	
Kabeltype / Type de câble	-	H07RN-F / 5G 2,5 mm ²	-	H07RN-F / 5G 2,5 mm ²
Kabellengte / Longueur de câble	-	1,5 m	-	1,5 m
Stekkers / Prises	BE-FR	BE-FR	Universeel • <i>Universel</i>	

ISO 9001



LM 46134

code							min.	€
LM 46134		5420000047129	240 x 170 x 80 mm	0,622 kg	-	2	1	44,30
Met kabel • Avec câble								
LM 46138		5420000047136	240 x 170 x 80 mm	1,002 kg	-	2	1	119,00



LM 46138



	LM 46134	LM 46138
Invoer / Entrée	1 x CEE 16A - 3P - 230V	
Uitvoer / Sortie	3 x CEE 16A - 3P - 230V	
Kabeltype / Type de câble	-	H07RN-F / 3G 2,5 mm ²
Kabellengte / Longueur de câble	-	1,5 m
Stekkers / Prises	Universeel • <i>Universel</i>	

ISO 9001

code							min.	€
LM 46478		5420000047150	200 x 100 x 80 mm	0,459 kg	-	5	1	37,10
LM 46413		5420000047143	295 x 190 x 100 mm	1,118 kg	-	2	1	84,00



LM 46478



LM 46413

	LM 46478	LM 46413
Invoer / Entrée	1 x CEE 16A - 5P - 400V	1 x CEE 32A - 5P - 400V
Uitvoer / Sortie	3 x 16A - 250V	3 x CEE 32A - 5P - 400V
Stekkers / Prises	BE-FR	Universeel • <i>Universel</i>

NEW



Max. 6400 W

LM 47930
 LM 47923

**Met zekering
Avec fusible**

Max. 12800 W

LM 47986
 LM 47954

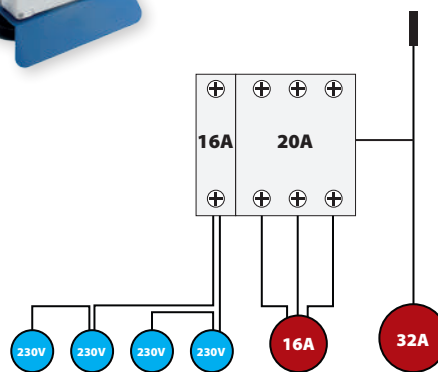

code								min.	€
------	--	--	--	--	--	--	--	------	---

LM 47930		5420000067127	414 x 316 x 164		2,500 kg	42	1	1	116,00
LM 47923		5420000067110	414 x 316 x 164		2,500 kg	42	1	1	116,00
Met zekering • Avec fusible									
LM 47986		5420000067103	402 x 322 x 164		3,900 kg	42	1	1	197,00
LM 47954		5420000067097	402 x 322 x 164		3,900 kg	42	1	1	197,00

	LM 47930	LM 47923	LM 47986	LM 47954
Kabeltype / Type de câble	H07RN-F / 5G 2,5 mm ²	H07RN-F / 5G 2,5 mm ²	H07RN-F / 5G 4 mm ²	H07RN-F / 5G 4 mm ²
Kabellengte / Longueur de câble	1,5 m	1,5 m	4 m	4 m
Max. Watt	6400W	6400W	12800W	12800W
Invoer / Entrée	CEE 16A - 5P	CEE 16A - 5P	CEE 32A - 5P	CEE 32A - 5P
Uitvoer / Sortie	2 x 400V (16A) 4 x 230V (FR/BE)	2 x 400V (16A) 4 x 230V (SCHUKO)	400V (1 x 32A - 1 x 16A) 4 x 230V (FR/BE)	400V (1 x 32A - 1 x 16A) 4 x 230V (SCHUKO)
Stekkers / Prises	 F B	 D L	 F B	 D L

**THERMOPLASTISCH GEÏSOLEERDE VERDEELKASTEN : SERIES IMST - EN 61439
COFFRETS DE DISTRIBUTION ISOLÉS THERMOPLASTIQUES : SERIES IMST - EN 61439**

- handige, robuuste, mobiele verdeelkast gemaakt van schokbestendige polyamide
- met draagbeugel
- stapelbaar, met opbergsysteem voor de aansluitkabel

- coffret de distribution pratique, robuste, mobile fabriqué en polyamide résistant aux chocs
- avec poignée de transport
- empilable avec rangement pour le câble



LM 47110

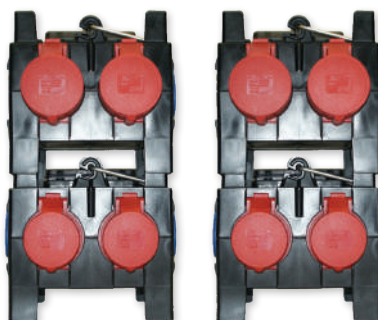

- ruimtebesparende opslag, boxen zijn stapelbaar
- gain d'espace de stockage car les boîtiers sont empilables

**Met zekering
Avec fusible**



LM 47117

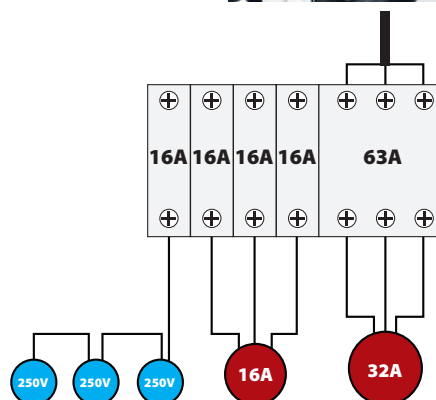

EN 61439

code							min.	€
LM 47110		5420000047167	200 x 197 x 197 mm	1,704 kg	-	1	1	136,00
Met kabel en zekering • Avec câble et fusible								
LM 47117		5420000047174	200 x 197 x 197	3,776 kg	-	1	1	371,00

	LM 47110	LM 47117
Invoer / Entrée	1 x CEE 16A - 5P - 400V	1 x CEE 32A - 5P - 400V
Uitvoer / Sortie	2 x CEE 16A - 400V 4 x 16A - 250V	1 x CEE 32A + 1 x 16A - 400V 3 x 16A - 250V
Zekering / Fusible	-	63 A
Kabeltype / Type de câble	-	HO7RN-F 5G 4 mm ²
Kabellengte / Longueur de câble	-	2 m
Stekkers / Prises		

PLUS



AAA

ref. PS 040001



AA

ref. PS 040005

**LANGDURIG VERMOGEN GEGARANDEERD !**

Duracell Plus Power staat voor betrouwbare prestaties en langdurig vermogen in een brede waaier van apparaten voor dagelijks gebruik. U kunt vertrouwen op Duracell Plus Power om uw afstandsbedieningen, cd-spelers, gemotoriseerd speelgoed, zaklampen, tandenborstels enz. van spanning te voorzien. Tot + 40 % meer vermogen (in digitale camera's, in vergelijking met Simply Duracell AA, verschillen de resultaten per apparaat). Langdurig vermogen gegarandeerd. Best geschikt voor een brede waaier van veelgebruikte apparaten. Verkrijgbaar in AA en AAA.

100 % getest voor spanning en tegen lekkage.**PUISSANCE LONGUE DURÉE GARANTIE !**

Duracell Plus Power vous offre une performance fiable et une puissance longue durée pour un large éventail d'appareils du quotidien. Vous pouvez compter sur Duracell Plus Power pour alimenter vos télécommandes, lecteurs de CD, jouets motorisés, lampes de poche, brosses à dents, etc... Jusqu'à 40% de puissance en plus (dans un appareil photo numérique par rapport aux piles Duracell Simply AA les résultats peuvent varier en fonction des appareils). Conçues pour une puissance longue durée pour un large éventail d'appareils du quotidien. Disponibles au format AA et AAA.

100% testé contre les fuites.

code				#/blister				min.	€
PS 040001		5000394018457	AAA / LR03	4	0,011 kg	-	10	1	6,32
PS 040005		5000394017641	AA / LR6	4	0,023 kg	-	20	1	6,32

PRO Power

**PROCELL®**

PROFESSIONAL BATTERIES BY DURACELL®

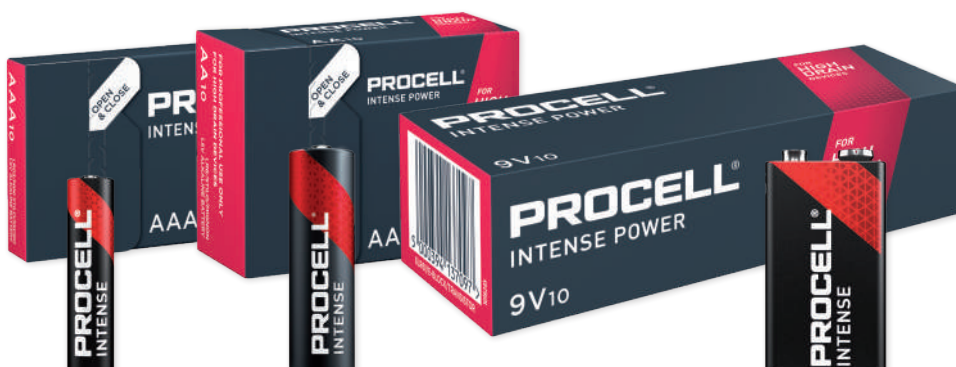

AAA

ref. PS 12710

AA

ref. PS 12709

9V

ref. PS 12713

De batterij voor de professionele gebruiker met langere levensduur

- Levert tot 30% meer vermogen tegen de meest voordelige prijs.
- Ontworpen om langer mee te gaan en verpakt voor grootverbruik en professionals.
- Meest geschikt voor professionele toestellen met hoog verbruik zoals zaklantaarn en andere krachtige apparaten.

La batterie pour les utilisateurs professionnels avec une longue durée de vie

- Fournit jusqu'à 30% de puissance en plus pour un prix plus avantageux.
- Conçu pour durer plus longtemps et emballé pour les grands consommateurs et professionnels.
- Idéal pour les appareils professionnels à forte consommation tels que lampe de poche et autres appareils puissants.

code				#/box				min.	€
PS 12710		5000394136939	AAA / LR03	10	0,120 kg	-	10	10	7,74
PS 12709		5000394136830	AA / LR06	10	0,244 kg	-	10	10	8,37
PS 12713		5000394137097	9V / 6LR61	10	0,472 kg	-	5	5	28,04

AAA

ref. PS 041030

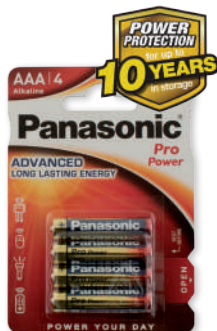

AA

ref. PS 041025



C

ref. PS 041015



D

ref. PS 041020



9V

ref. PS 041010



- Alkaline kernproducten : ontworpen voor betrouwbare stroomvoorziening op alle plaatsen en alle tijdstippen
- Een volledig assortiment
- Ideaal voor apparaten met een hoog gemiddeld verbruik

- Piles alcalines coeur de gamme : conçues pour une alimentation fiable à tout moment et en tous lieux
- Un assortiment complet
- Idéales pour les appareils à consommation moyenne et élevée

code				#/blister				min.	€
PS 041030		5410853039006	AAA	4	0,011 kg	60	12	1	4,71
PS 041025		5410853038948	AA	4	0,023 kg	60	12	1	4,71
PS 041015		5410853038917	C	2	0,070 kg	60	12	1	4,71
PS 041020		5410853038887	D	2	0,143 kg	60	12	1	7,43
PS 041010		5410853038979	9V	1	0,044 kg	60	12	1	5,36

Rechargeable



HONDERDEN KEREN OPLAADBAAR !

Meest duurzame oplaadbare batterij, werking tot 5 jaar of 400 laadbeurten gegarandeerd. Vervaardigd met NiMH technologie voor optimale prestatie, zelfs bij lage temperaturen. Meest geschikt voor toestellen die veel energie verbruiken.

LA PILE DURABLE, FOURNIE CHARGÉE.

Pile rechargeable la plus durable, fonctionnement jusqu'à 5 ans ou 400 recharges garanti. Fabriquée avec la technologie NiMH pour des prestations optimales, même à des températures basses. Le plus approprié pour des appareils qui consomment beaucoup d'énergie.

AAA

ref. PS HR03-PRE4



AA

ref. PS HR06-PRE4



code				Min. cap.	#/blister				min.	€
PS HR03-PRE4		5000394203822	AAA / HR03	900 mAh	4	0,120 kg	-	10	1	22,37
PS HR06-PRE4		5000394057043	AA / HR6	2500 mAh	4	0,120 kg	-	10	1	22,37

45 minuten lader om AA- of AAA-NiMH-batterijen op te laden.

Geschikt voor alle oplaadbare AA- en AAA-NiMH-batterijen. Eenvoudig opladen, uitstekende prijs-kwaliteitverhouding.

Charge les piles AA-NiMH et AAA-NiMH en 45 minutes.

Adapté à toutes les piles de type AA-NiMH et AAA-NiMH. Facile d'utilisation et excellent rapport qualité-prix.

code			Opladtid / Temps de charge	Pack				min.	€
PS 045050		5000394117211	45 min.	Oplader/chargeur + 2 x AA incl. + 2 x AAA incl.	0,208 kg	-	6	1	44,20

PS 045050



LITHIUM Power



CR-123

ref. PS 041115



LRV08 / MN21-23GA

ref. PS 041110



- Zeer lange levensduur
- Ideaal voor oa. fotoapparaten, camera's, rookdetector, ...
- Très longue durée de vie
- Idéal pour par exemple appareils photos, caméras, détecteurs de fumée, ...

code				#/blister				min.	€
PS 041115		5410853017097	CR-123	1	0,017 kg	-	10	1	6,34
PS 041110		5410853057345	LRV08/MN21-23GA	1	0,017 kg	-	10	1	2,35

Knoopcel batterijen • Piles bouton



0%

Mercury toegevoegd
de Mercure ajouté

- Lithium Power knoopcel batterijen zijn ontworpen om een krachtig, betrouwbaar en duurzaam voeding te bieden.
- Zeer lange levensduur
- Gebruikt voor horloge, afstandsbediening, rekenmachine, fotoapparaat, ...
- Les piles bouton Lithium Power sont conçues pour fournir une alimentation puissante, fiable et durable.
- Très longue durée de vie
- Utilisé pour montres, commande à distance, calculatrice, appareil photo, ...

CR-2016

ref. PS 041120

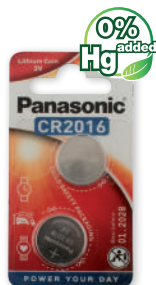

CR-2025

ref. PS 041125



CR-2032

ref. PS 041130



CR-2450

ref. PS 040010



SR44S

ref. PS 040015



code				#/blister				min.	€
PS 041120		5025232060665	CR-2016	2	0,002 kg	-	12	1	4,13
PS 041125		5025232060672	CR-2025	2	0,002 kg	-	12	1	4,13
PS 041130		5025232060689	CR-2032	2	0,003 kg	-	12	1	4,13
PS 040010		5000394030428	CR-2450	1	0,002 kg	-	10	1	4,82
PS 040015		5000394013858	SR44S	2	0,002 kg	-	10	1	7,64

Blokbatteerij 6V • Batterie 6V



Panasonic

code						min.	€	
LM 1100	vrac	5420000029033	4R25 K/Zn 9 Ah	510 g	1008	24	6	3,90
PS 041500		5410853033141	4R25 RZ/B 7,4 Ah	700 g	-	12	1	11,71

